

Design of Balanced Output High-Voltage Nanosecond Pulse Source for Symmetrical Antenna

YANG De-qiang, PAN Jin, ZHAO Zhi-qin, and NIE Zai-ping

(School of Electronic Engineering, University of Electronic Science and Technology of China Chengdu 610054)

Abstract Time-domain impulse generator is a very important unit in time-domain ultra-band radar systems. Most time-domain impulse antennas are symmetrically designed which require balanced output pulse generators in order to realize wideband matching. Aiming to solve the compatible problem of high voltage and balanced output, which commonly exists in high-voltage pulse generators, this paper designs a new pulse generator circuit, the cascade Marx circuit with balanced output. With this generator and a loaded bow-tie antenna, a 300 V nanosecond pulse was generated. The measured result validates the effectiveness of the proposed pulse generator.

Key words balanced output; Marx circuit; nanosecond pulse; symmetrical antenna

适合对称天线的平衡输出高压纳秒级脉冲源研究

杨德强, 潘 锦, 赵志钦, 聂在平

(电子科技大学电子工程学院 成都 610054)

【摘要】时域脉冲源是时域超宽带雷达系统中的重要部件, 时域脉冲天线大多采用对称形式, 如果用非平衡高压脉冲源激励, 难以实现很好的宽带匹配。为此设计了一种新的电路形式, 采用平衡输出的Marx电路级联, 解决了脉冲源高幅度和平衡输出不能兼顾的问题。利用与对称天线进行的纳秒级脉冲收发实验验证了该电路的良好性能。

关键词 平衡输出; Marx电路; 纳秒级脉冲; 对称天线

中图分类号 TN784.1

文献标识码 A

doi:10.3969/j.issn.1001-0548.2011.03.007

The time-domain impulse has been widely used in ground penetrating radar (GPR) for concealed targets detection^[1]. The antennas used for transmission are usually symmetrically designed in order to realize wideband matching^[2-4]. Therefore, pulse generator with balanced output is adopted. In radar system, the detection range is a very important parameter. Usually high amplitude output of the pulse generator is demanded for long distance detection. However, it is impossible for a single avalanche transistor to produce such high amplitude output (e.g. hundreds of volts). Cascade Marx circuit can significantly promote the output voltage. But this kind of circuit usually provides unbalanced output^[5-8]. Therefore, an unbalanced-to-balanced conversion should be taken on the symmetrical antenna which is extremely difficult for

ultra-band time-domain pulse. In order to solve the compatible problem of high voltage and balanced output, this paper designs a new pulse generator circuit, which uses the cascade Marx circuit with balanced output. Experimental result shows that the new pulse generator can meet the requirements of balanced output and high amplitude of a bipolar pulse.

1 Design of the Symmetrical Marx Circuit

In recent years, due to the emergence of high performance avalanche transistors, it is possible to miniaturize the size of solid high-voltage pulse generator, which has been widely used in the pulse circuits. When the transistor's collector voltage is high enough, its amplitude of electric field in the charge

Received date: 2010 - 11 - 29; Revised date: 2011 - 02 - 25

收稿日期: 2010 - 11 - 29; 修回日期: 2011 - 02 - 25

Foundation item: Supported by the NSFC (60771042), 111 project (B07046), Supported by NSAF(10776003)

基金项目: 国家自然科学基金(60771042); 高等学校学科创新引智计划(B07046); 国家自然科学基金委与中国工程物理研究院资助(10776003)

Biography: Yang De-qiang, Research interests include microwave engineering and antenna, transient electromagnetic.

作者简介: 杨德强(1971 -), 男, 博士生, 主要从事微波技术和天线以及瞬变电磁场方面的研究。

region of the junction is many times higher than that at the normal low-pressure condition. The carriers in the collector are accelerated by the strong electric field, leading to huge energies. Their collisions with the lattice give rise to new electron-hole pairs. Then the newly generated electron-hole pairs will be accelerated again in the electric field. Repeating the above process, the currents flow through the collector will rapidly grow and bring avalanche multiplication phenomenon. This is the transistor's avalanche multiplication phenomenon. The obvious multiplication phenomenon of the transistor is called as the avalanche transistors.

Fig. 1 gives the circuit diagram of a pulse generator. The base of the avalanche transistor is reverse biased. The working voltage reaches the requirements of avalanche zone. Before the arrival of the trigger pulse, the avalanche transistor is cut off. The VCC voltage source charges the capacitor C_2 through the R_4 resistor and the R_3 resistor, as illustrated by the line

arrives, the transistor turns on rapidly. The capacitor C_2 rapidly discharges through its own small resistance to the ground. Since the voltage across the capacitor can not abruptly jump, a negative pulse in the output terminal will be generated. Confined by the voltage characteristics of the transistor, usually this transistor can only produce tens of volts pulse. If one wants to generate larger pulse, cascade circuit is always adopted.

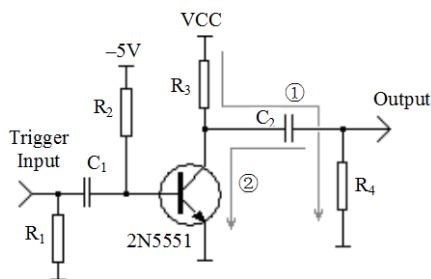

Fig. 1 The circuit diagram of a pulse generator

Fig. 2 is a principle sketch map of the Marx circuit. When the switchers S turn off, all the capacitances C are on charge. When the switchers turn on, all the capacitances discharge which produce a high-voltage pulse. The theoretical output voltage of the pulse is $U_{out} = N \times VCC$, where N is the total number of the capacitances, and VCC is the voltage of the electric power. The avalanche transistor is a very suitable switcher. Using avalanche transistor can

miniaturize the size of the pulse generator.

The same capacitances can be set for each capacitor at all levels, i.e. $C_1 = C_2 = \dots = C_N$, hence the actual capacitance in the discharge process equals to $C = C_N / N$. The smaller the capacitance is, the lower the pulse amplitude will be. Nevertheless, the pulse will be narrower. Whereas, the bigger the capacitance is, the higher the pulse amplitude is, but the wider the pulse width will be. Vice versa.

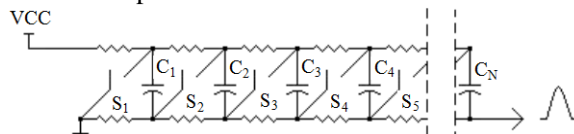

Fig. 2 The principle sketch map of the Marx circuit

As shown in Fig.3, when the avalanche transistors are biased at the critical avalanche state, the power charges for capacitors C_2 and C_3 through the resistors R_1 , R_2 and R_4 . When a trigger pulse arrives, the transistor will be avalanche breakdown. Because the voltages across the capacitors can not abruptly jump, a positive pulse and a negative pulse at the output port will be generated.

Then they can be used as a balanced symmetrical output pulse source directly connected to a symmetrical antenna. Different from the non-symmetrical pulse, it does not need the unbalanced-to-balanced conversion. It can directly match the time-domain wideband antenna. Therefore, the symmetrical pulse is very important. It can improve the antenna radiation efficiency and reduce the pulse tail.

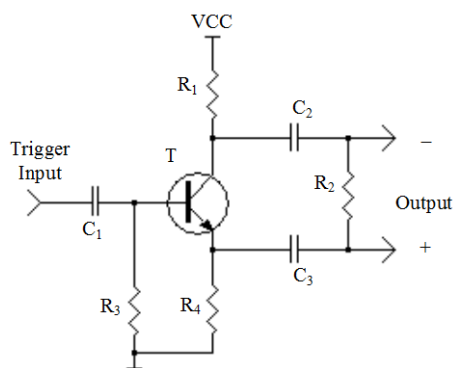

Fig. 3 The trigger port of symmetrical Marx circuit with balanced output

Because of the breakdown voltage characteristics of the transistor in Fig. 3, usually it is very difficult to generate a pulse which is higher than 100 V using single level Max circuit. Some references also proposed how to generate pulses with hundreds or

even thousands volts using cascade circuit. But they are all non-symmetrical pulses. It has never reported how to generate a symmetrical nanosecond pulse with hundreds volts with cascade circuit. In this paper, a cascade Marx circuit with balanced output is proposed.

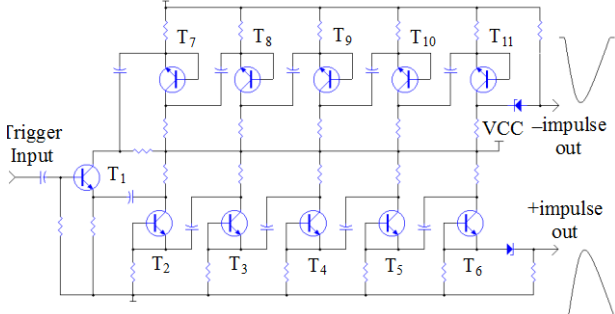

Fig. 4 The sketch map of the 5 cascade stages balanced output Marx circuit

The new cascade Marx circuit with balanced output proposed in this paper is shown in Fig. 4. The amplitude of the input trigger is larger than 1 V and the pulse wide is less than 10 ns. The trigger signal is transformed into one positive and one negative trigger pulses by T₁. The positive trigger pulse makes the cascade Marx circuits which consist of the avalanche transistors T₂~T₆ avalanche continuously to produce a positive high amplitude pulse. At the same time, the negative trigger pulse makes the serial Marx circuits which consist of the avalanche transistors T₇~T₁₁ avalanche continuously to produce a negative high amplitude pulse. The amplitude of the output pulse generated by this circuit can be up to ±10 kV .

2 Experimental Results

A balanced output pulse generator with 0.5 ns wide and ±300 V amplitude has been realized. Fig. 5 and Fig. 6 show the photographs of the circuit board and the antenna.

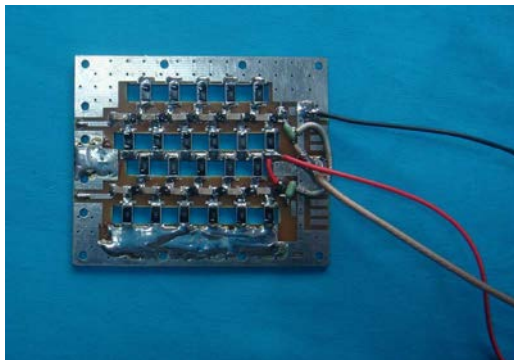

Fig. 5 The photographs of the circuit board

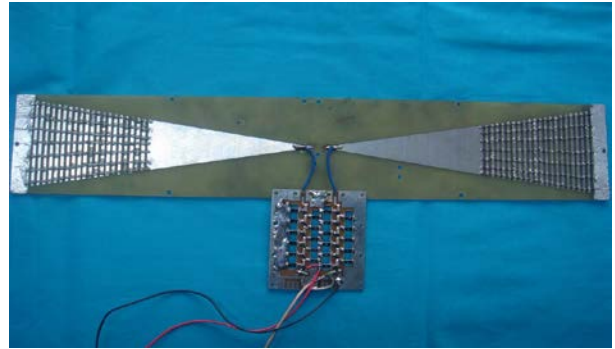

Fig. 6 The photographs of the circuit board and the antenna

The experiment of transmitting/receiving a nanosecond pulse is performed by combining the new designed circuit with a bow-tie. The corresponding wave form was recorded by the LeCroy wavepro 7Zi oscillograph as shown in Fig. 7. The tailing of the waveform is very small. The waveform in Fig. 7 is better than that in Ref. [2]. The amplitude and the width of the pulse in Fig. 7 are 3.375 V and 0.5 ns, respectively.

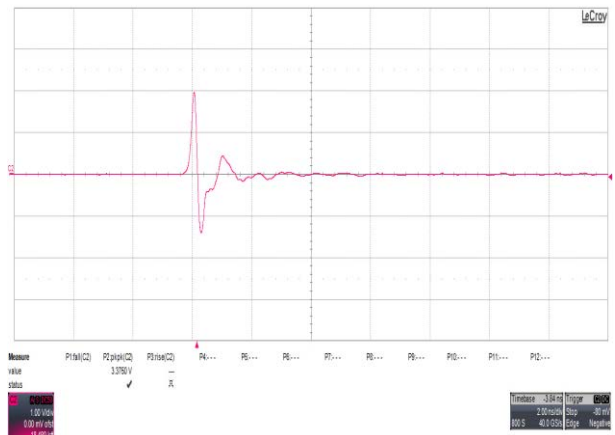

Fig. 7 The wave form in the transmitting/receiving experiment

3 Conclusions

The high-voltage nanosecond pulse generator with balanced output designed in this paper possesses prominent advantages when performing with the symmetrical antenna. Due to the feature of the balanced output, complicated unbalanced-to-balanced conversion can be avoided. The design provides an effective way for producing high amplitude pulse with balanced output. Experimental result has proved the effectiveness of the idea in the paper.

(下转第410页)